

SOAP DISPENSERS



ML602AR

Ellipse Soap Dispenser in Satin Stainless Steel

Specification

Material	#304 Stainless Steel, 0.8mm Thick
Finish	Satin Stainless Steel
Mounting	Surface Mount Concealed Fix
Dimensions	209mmH x 122mmW x 129mmD
Capacity	1.2L
Features	Pump action soap dispenser valve Impact-resistant liquid level indicator Lockable hinged lid (key provided) Rounded fascia
Consumable Guide	A Commercial Grade Liquid Soap with a Viscosity range of 1,000 – 5,000 cps (centipoises) and a PH level between 6.50 – 9.00 should be used in this dispenser to ensure the dispenser performs at an optimal level. <i>* Any liquids not within these ranges may cause the unit to operate at a sub-optimal level, fail or damage the unit and could void the Metlam Australia product warranty.</i>
Note	* This unit is accessible compliant when installed in accordance with AS1428.1. guidelines.

Downloads & Resources

[Care & Maintenance](#)
[Installation instructions](#)
[Auto cad](#)
[Associated Videos](#)
[Stainless Steel Cleaning & Maintenance](#)
[Looking after your Metlam Australia Soap Dispenser](#)

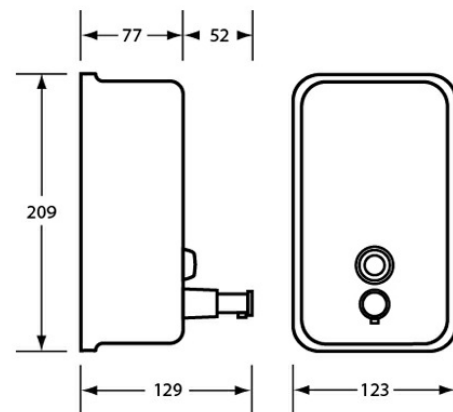

The photographs and line drawings of the products presented above are representational only. Metlam Australia Pty Ltd reserves the right to, and from time to time, make changes and improvements in design and dimensions.